

CIRCULAR DIES

BS Standard 1951 Inch

There are two types of dies in the range, the standard Bs 1172 1951 style which are "inch" outside diameter and are of the split die type. The die stock is provided with 3 screws, the centre screw should just be touched into the vee split and the two side screws touching into the closing dimple. the centre screw should be retracted by 1/4 turn. the die is ready to cut a thread which should be size to a medium fit.

Adjusting the Die

Avoid trying to open out the die to cut an oversize thread as this will cause rubbing on the workpiece. Adjusting the die down should be done by 1/8 turn (45°) on the dimple screws and both screws adjusted alternately, and evenly.

DIN 223, ISO 2568 B.S. Standard 1127 (1990)

These are solid dies with Metric outside diameters. They have no split for adjustment, they have Gun Nose geometry which throws the swarf forward of the tool, so that swarf does not fill the clearance holes.

The dies are designed to cut a 6g tolerance.

The Gun nose design is very effective for tough and work hardening materials like stainless steel.

NOMENCLATURE

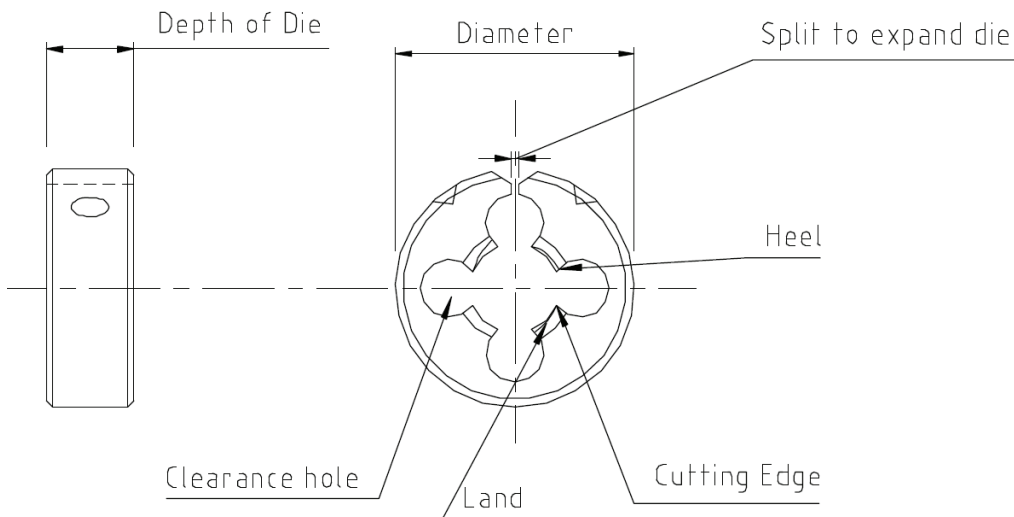

USE OF CIRCULAR DIES

Prepare the workpiece by chamfering the end at 45°, 90° inclusive. This will allow the die to start cutting squarely to the rod or bolt. Failure to do this will put sudden loads onto the cutting edges, resulting in the thread cutting off-centre, trying to straighten the cut will result in chipping. In extreme cases the one side of the split die will lift and the other drop, the die will split at the clearance hole opposite the vee groove.

Always ensure that the die is concentric and squarely presented to the workpiece.

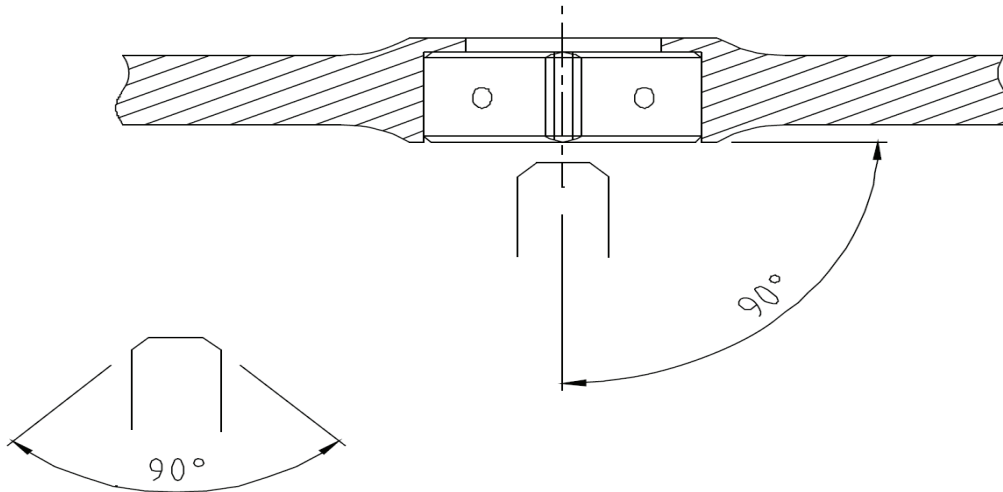

HEXAGONAL DIENUTS

Hexagonal dienuts are normally used by hand, for reclaiming or cleaning of existing threads. They are generally used "On Site" and are more robustly constructed for this type of work. They have lower cutting rake, and are not suitable for cutting a new thread. We understand that it is often used in exceptional circumstances for this type of application, but extreme care must be exercised as it will tend to cut a wavering thread as there is no diestock to keep it square to the workpiece.

Diameter across driving flats

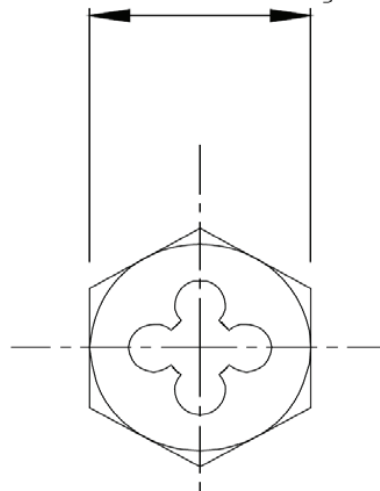

Width of nut

