

## Drill Points According To DIN 1412

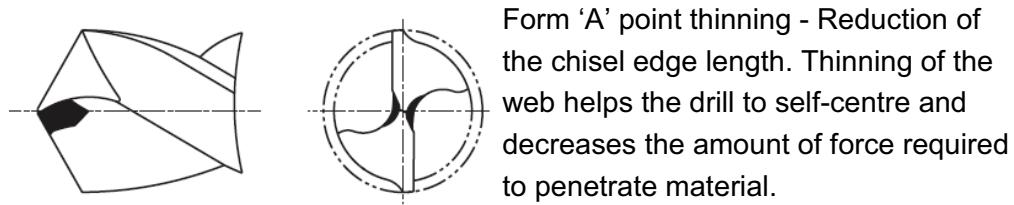

Form 'A' point thinning - Reduction of the chisel edge length. Thinning of the web helps the drill to self-centre and decreases the amount of force required to penetrate material.

### DIN 1412 Form A Point Thinning

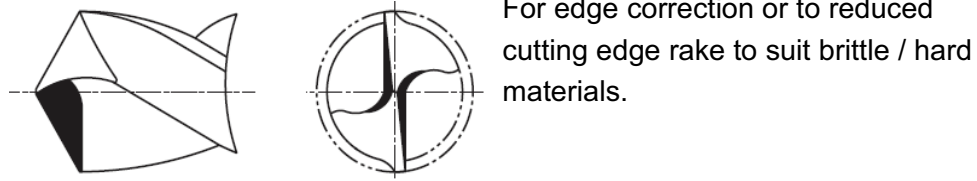

For edge correction or to reduced cutting edge rake to suit brittle / hard materials.

### DIN 1412 Form B

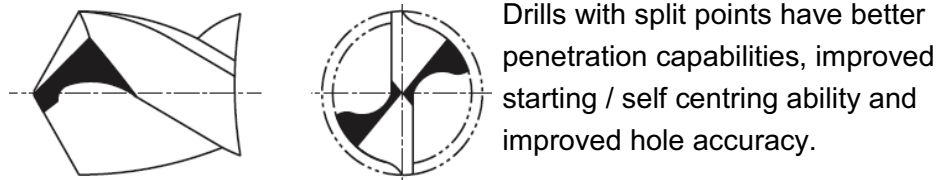

Drills with split points have better penetration capabilities, improved starting / self centring ability and improved hole accuracy.

### DIN 1412 Form C & ANSI Split Point

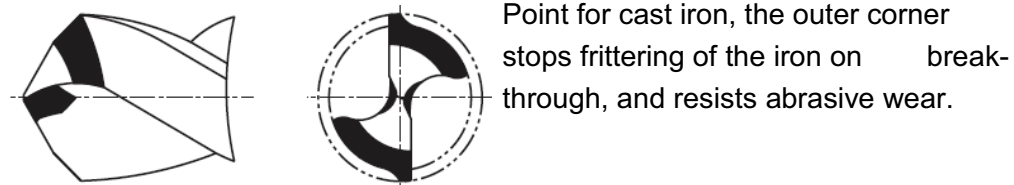

Point for cast iron, the outer corner stops frittering of the iron on break-through, and resists abrasive wear.

### DIN 1412 Form D Double Angle Point

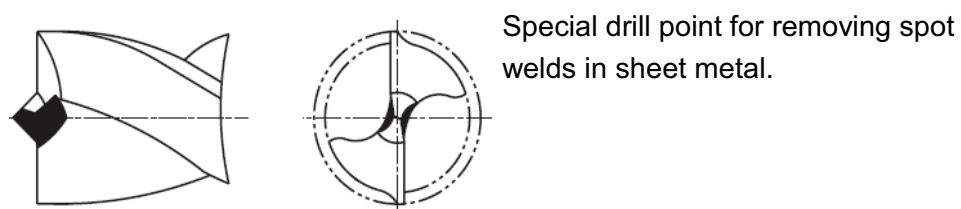

Special drill point for removing spot welds in sheet metal.

### DIN 1412 Form E Spot Weld

## TWIST DRILL NOMENCLATURE

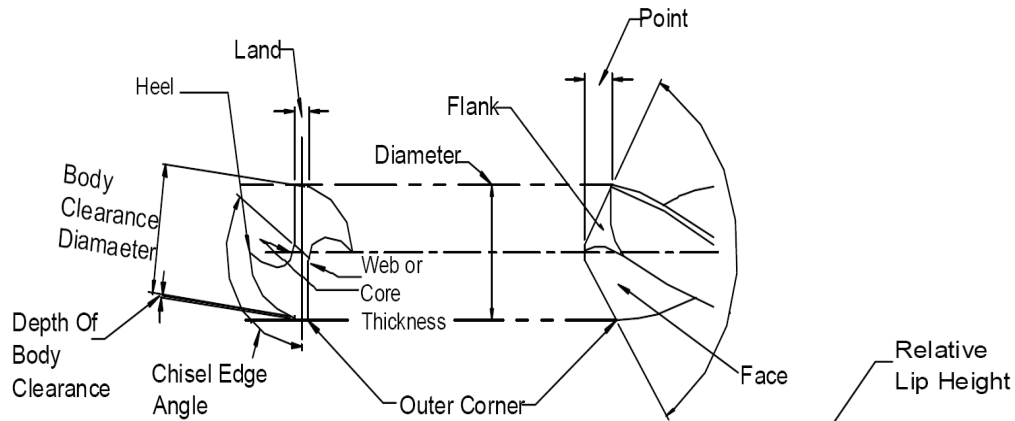
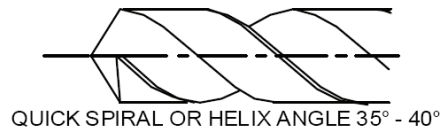
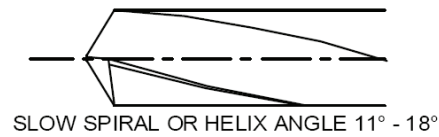
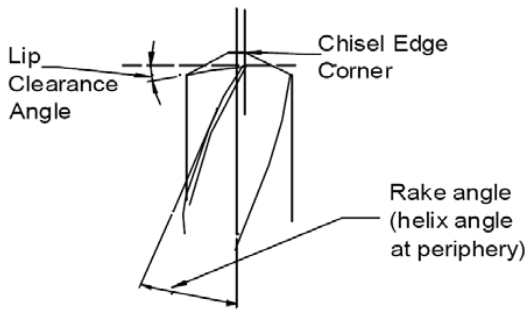
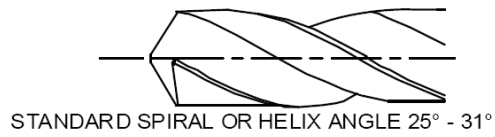
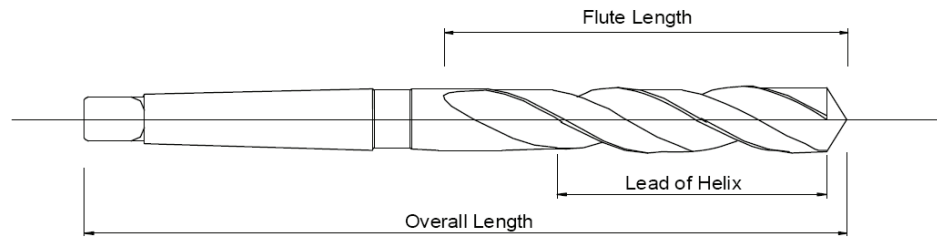
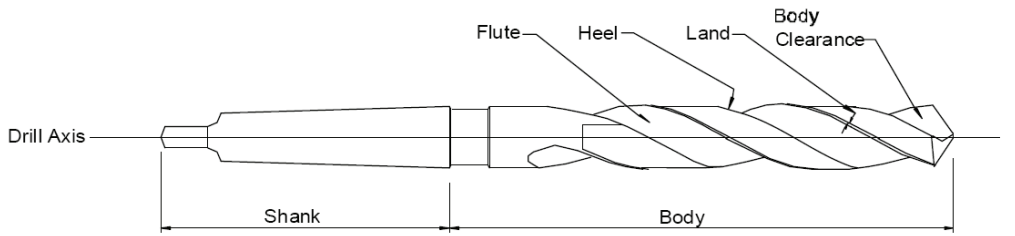



## DRILLING PRACTICE

The flute form, web thickness and helix angle of the standard drill are suitable for most materials producing semi-continuous chips.

Drilling sizes of 13mm and smaller in soft materials which produce continuous chips, e.g. copper, aluminium, a bright finish fast helix drill may be required to remove the swarf more effectively. Conversely on materials producing discontinuous chips like brass, gunmetal and some plastics, a slow spiral is preferable.

For effective drilling, the rigidity of the drill and work piece are most important. The shorter the flute length the more rigid the drill. Long drills must be adequately supported to reduce vibration, or stage drill as opposite.

Heavy duty thick web drills may be necessary on the more difficult materials, or when work lacks rigidity. These drills must be point thinned or have split points (see page 17).

The following are important in drill use:

- 1 Clamp the work-piece securely.
- 2 Select the correct speed and feed.
- 3 Use an appropriate coolant and lubrication.
- 4 When using a taper shank drill use a soft face hammer or wood block to for insertion.
- 5 Ensure the shank is securely held. Avoid using worn sockets or drill chucks as the drill may slip during use.
- 6 Regrind the point before it dulls, do not force a worn drill.
- 7 Deep hole drilling, withdraw frequently to clear the chips. Deep holes start at 4 times diameter.
- 8 Opening out existing hole, **do not use** a 2 flute twist drill, use a 3 or 4 flute core drill. Pilot holes should be 1.5 times the chisel edge length.
- 9 Stainless, Manganese and high tensile steels, use an automatic feed throughout the drilling cycle. Do not allow the drill to dwell as it will cause work-hardening; use a slower speed and heavier feed than on easier machined materials.

## DEEP HOLE SERIES DRILLING

Holes deeper than nominally three times the drill diameter may need special methods to clear the swarf especially when drilling horizontally with standard flute design.

### Series Drilling

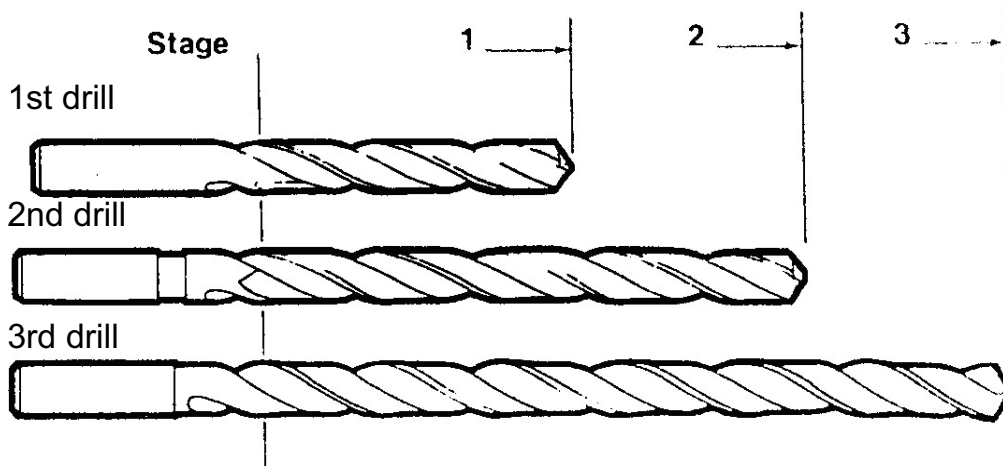

A series of longer drills may be used successively.

### FIRST DRILL

This should be either a stub drill or a jobber drill used down to the flute length and pecking at intervals after 3 times diameter in depth to clear the swarf. Alignment of the first drill is very important as all subsequent drills will wander further from this location.

### SECOND DRILL

A long series drill to be used as above with pecking about every diameter in depth.

### THIRD & SUCCESSIVE DRILLS

Extra length drill of increasing flute lengths may be used successively to the required depth, pecking may be required at only half the diameter on extreme depth.

### PARABOLIC FLUTE DRILLS

Are specifically designed for deep hole drilling and clearing the swarf without pecking down to 10 times the diameter on materials that produce long continuous swarf. Parabolic drills are stocked from stub to extra length drills.

## RESHARPENING OF TWIST DRILLS

Unless a drill is correctly resharpened the efficiency is greatly reduced. The general features to be observed are:

1. Resharpen before the drill becomes too dull
2. Maintain
  - a. The correct point angle
  - b. Correct lip clearance
  - c. Equal cutting edge length
  - d. Equal cutting edge angles
  - e. Correct web thickness
  - f. Relative lip height to a close tolerance
  - g. Never quench the drill in water to cool it. Never grind using a trickle of water. These two methods are likely to produce hair line surface cracks owing to the local heating and quenching. Grind either under a gush of water, or perfectly dry and allow to air cool.

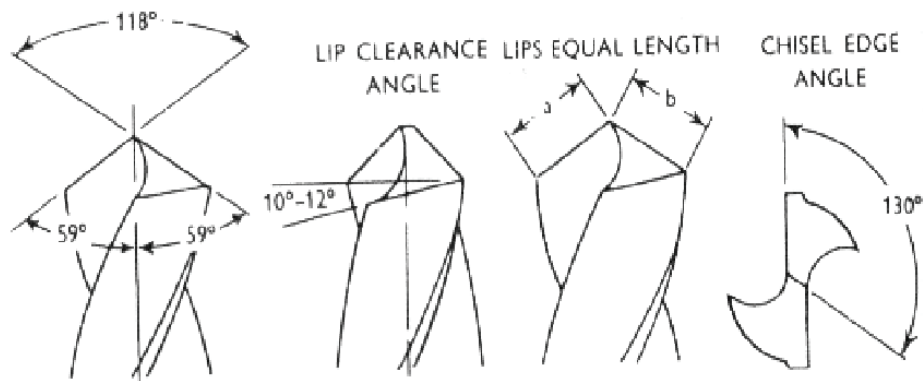

### Web Thinning



The thickness of the web increases from the point back to the flute run out. As the drill is pointed back the web should be thinned to approx. 10% of the drill diameter using a grinding wheel of half the flute width. Excessive thinning may weaken the drill causing splitting up the web.

### Chipbreaking



A thin radiused wheel can be used to grind grooves across the cutting face which assists chipbreaking. Reducing the peripheral speed and increasing the feed rate, where conditions allow, can also produce a discontinuous chip.

**Acute Point Angle**

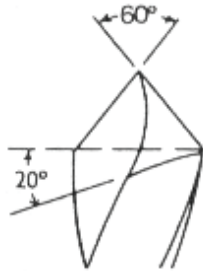

Point angles down to 60° can be used to reduce the tendency of brittle materials such as Bakelite, to flake away on the undersurface as the drill breaks through. The acute angles when applied to standard drills result in convex cutting edges, see point correction.

**More Obtuse Point angle**

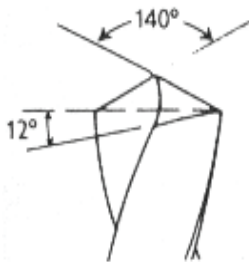

A flatter point angle up to 140° inclusive can be advantageous on high tensile steel and work hardening materials. This angle causes the cutting lips to become concave which weakens the outer corners. It is preferable to use specially designed drills for more difficult materials.

**Point Correction**



The face of the flute along the cutting lip is ground to reduce the helix angle for brittle materials. A similar technique can be used to correct convex cutting edges. It is important that the circular land is not ground away.

This flat cutting edge will assist when using a two flute drill to open out an existing hole.

**Double Angle Point**



The standard 118° point is maintained on the drill for half the lip length. The outer half is then ground at 90 to give a reinforced cutting edge, thus ensuring the corner is not destroyed in abrasive materials, such as cast iron.

**Split Point**

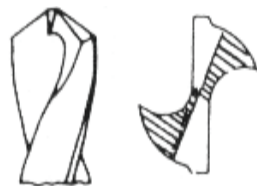

On thick web, heavy duty drills the chisel edge may be too wide to use web thinning, consequently a split point is required to produce an additional cutting edge at the centre.

Specialist drills for most materials are available, please consult the catalogue.

## Common Reasons for Drill Failure

### 1. OVERSIZE HOLE

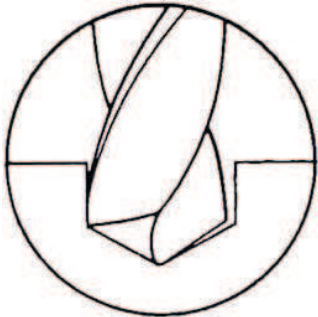

- a. Lips of unequal length, one lip doing all the work. Suggest: Re-grinding the drill.
- b. Chisel edge not central. Suggest: re-grinding the drill.
- c. Machine spindle out of true. Check for damage to chuck or spindle.

### 2. UNEQUAL CHIPS



- a. Lips of unequal length as in 1a. Long chip from one side indicates that it is doing all the work. Suggest: Re-grinding the drill.
- b. Drill point angle is off; low on one side and high on the other consequently the chisel edge will be off centre.
- c. Relative lip height; too great a difference.

### 3. SPLITTING UP THE WEB

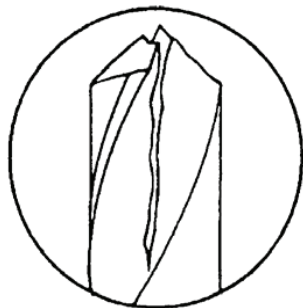

- a. Insufficient lip clearance. Suggest re-grinding drill.
- b. Too high a feed rate. Check recommended conditions.
- c. Striking drill point with hard object.
- d. Ejecting drill onto machine base. Both c. & d. cause bruising to the chisel edge, which will show up under use as a fracture.
- e. Surface cracks on the flanks can be caused by overheating when grinding and then quenching see item 2g on page 16.

**4. BROKEN TANG**

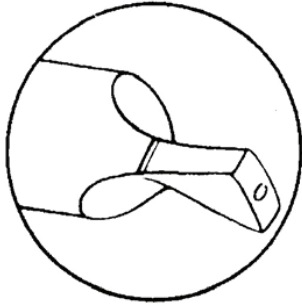

The tang is for ejection purposes only. Allowing the torque to be taken by the tang will result in breakage's Always ensure that the taper socket is free from foreign matter and damage, So that friction alone drives through the taper The positive helix angle of the drill, will, when opening out an existing hole pull the Morse taper out of contact, which will result in a broken tang. Pilot holes should only be 1.5 times the chisel edge.

**5. BREAKING DOWN OF OUTER CORNERS**

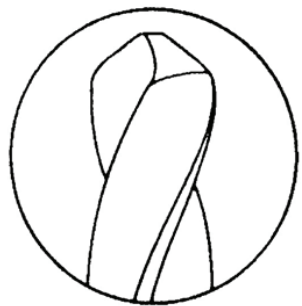

- a. Peripheral speed too high burning out the corners.
- b. Inadequate lubrication / coolant.
- c. Interrupted feed on work hardening materials.
- d. Work not supported adequately.
- e. Opening out existing holes.

**6. CHIPPING OF LIPS**

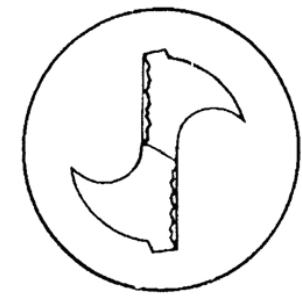

- a. Lip clearance too great.
- b. Feed rate too high.
- c. Drill surging on break through.
- d. Quenching drill on re-grinding.

**7. BREAKING OF DRILLS**

- a. Drill worn or improperly point ground.
- b. Drill slipping in drive.
- c. Drill flutes choking in swarf.
- d. Insufficient lip clearance.
- e. Work not rigid.
- f. Feed rate too high or drill pulling through on breakthrough.

## DRILL CUTTING SPEEDS

MATERIAL	HARD'S	SPEEDS & (FEEDS)		
<b>Steel</b>		Stub	Jobber	Long S
Leaded Free Cutting	120Hb	36 (5)	33 (4)	22 (3)
Low Carbon	150Hb	32 (5)	27 (4)	20 (3)
Medium Carbon	250Hb	27 (4)	22 (3)	17 (3)
Alloy Steel	250Hb	21 (4)	18 (3)	16 (2)
Alloy Steel Treated	300Hb	14 (3)	11 (2)	9 (2)
Alloy Steel Treaded	350Hb	9 (2)	7 (2)	6 (2)
<b>Stainless steel</b>				
Free Cutting	250Hb	16 (4)	14 (2)	12 (2)
Austenitic Non-Mag	250Hb	9 (4)	7 (4)	6 (3)
Duplex Alloys	300Hb	12 (3)	9 (3)	7 (2)
<b>Cast Irons</b>				
Plain Grey Cast	150Hb	35 (4)	33 (4)	25 (3)
SG & Malleable	250Hb	30 (4)	22 (4)	20 (3)
Alloy Cast	300Hb	19 (4)	17 (3)	15 (3)
<b>Titanium</b>				
Pure Titanium	200Hb	28 (4)	18 (4)	15 (3)
Titanium Alloys	300Hb	9 (2)	7 (2)	6 (2)
<b>Nickel</b>				
Pure Nickel	200Hb	12 (4)	14 (4)	10 (3)
Nimonic 75, Hasteloy	300Hb	10 (4)	9 (4)	7 (3)
Inconel 718	300Hb	7 (3)	5 (3)	3 (2)
<b>Copper Alloys</b>				
Pure Copper	100Hb	42 (5)	40 (4)	30 (3)
Brass Soft Yellow	150Hb	40 (5)	40 (5)	
Brass Tough Red	200Hb	37 (5)	37 (5)	
Hi-tensile Bronze	250Hb	28 (4)	25 (4)	23 (3)
<b>Aluminium</b>				
Soft & Extruded	100Hb	55 (7)	50 (6)	40(5)
Wrought & Treated	150Hb	45 (5)	40 (5)	30 (3)
Cast 5% Si	120Hb	40 (5)	35 (4)	30 (3)
Cast 10% Si	150Hb	33 (4)	30 (4)	27 (3)

Speeds given in Meters / min. Feeds In brackets(4).

Use cobalt drills, or H.S.S. at reduced speed of 66%.

Specialist drills are available for most material or difficult applications please consult catalogue for application orientated drills.

Use quick spiral Bright finish on aluminium, copper.

Use slow spiral Bright finish on brasses.

If quick or slow spiral not available, bright finish is a good alternative for non ferrous materials.

## SPEED CHART

Diameter Meters/min	1/8"	3/16"	1/4"	5/16"	3/8"	1/2"	5/8"	3/4"
	3	5	6	8	10	12	16	19
5	530	318	265	199	159	133	99	84
7	743	446	371	279	223	186	139	117
9	955	573	477	358	286	239	179	151
12	1273	764	637	477	382	318	239	201
15	1591	955	796	597	477	398	298	251
20	2122	1273	1061	796	637	530	398	335
22	2334	1401	1167	875	700	584	438	369
25	2652	1591	1326	995	796	663	497	419
<b>27</b>	<b>2865</b>	<b>1719</b>	<b>1432</b>	<b>1074</b>	<b>859</b>	<b>716</b>	<b>537</b>	<b>452</b>
30	3183	1910	1591	1194	955	796	597	503
35	3713	2228	1857	1393	1114	928	696	586
40	4244	2546	2122	1591	1273	1061	796	670
45	4774	2865	2387	1790	1432	1194	895	754
50	5305	3183	2652	1989	1591	1326	995	838

## FEED CHART

Diameter Feed Code	3	5	6	8	10	12	16	19
	Feed per revolution in mm's							
(1)	0.030	0.035	0.045	0.055	0.062	0.070	0.085	0.110
(2)	0.045	0.060	0.065	0.070	0.100	0.110	0.130	0.160
<b>(3)</b>	<b>0.062</b>	<b>0.080</b>	<b>0.095</b>	<b>0.120</b>	<b>0.140</b>	<b>0.150</b>	<b>0.160</b>	<b>0.210</b>
(4)	0.085	0.110	0.120	0.160	0.190	0.200	0.240	0.280
(5)	0.120	0.150	0.170	0.220	0.260	0.280	0.320	0.360
(6)	0.150	0.190	0.210	0.280	0.330	0.350	0.400	0.450
(7)	0.180	0.230	0.250	0.330	0.390	0.420	0.460	0.520

Feeds in Brackets (4) from speed chart above

Figure in **bold** are the best general purpose speed and feed for use on steel as a good starting point .

To convert Meters / Minute peripheral speed to RPM use formula:

$$\text{RPM} = \frac{\text{Meters Per Minute} \times 1000}{3.1416 (\pi) \times \text{Diameter in MM's}}$$

Penetration rate = RPM x Feed per revolution.

Speeds and Feeds are given as starting points, the design of the drill can effect the performance and life.